

Town of Bartlett

Print Now

Parcel ID: 2RT302 000167 000R00 (CARD 1 of 1)
 Owner: PANNO LLC
 Location: 342 US RT 302
 Acres: 8.307

General

Valuation	
Building Value:	\$1,052,900
Features:	\$25,900
Taxable Land:	\$380,600
<hr/>	
Card Value:	\$1,459,400 
Parcel Value:	\$1,459,400

Listing History	
List Date	Lister
06/27/2011	DJRL

Districts	
District	% In Dist.
UTIL-ALL OTHERS	100
NOCO & KEAR	000
NOCO &	000

Notes: BERNERHOF REST& INN; 95 DESUBD LINE W/175R09\2001 ENTRANCE CANOPY; 02/03 VOL MERG W/175R04; PTO 1042 ISSUED 7/30/2010 FOR RENOV; 2011 - BERNERHOF INN - 12RMS EACH W/ FULL BATH, 2 OF ROOM ARE SUITES W/ SEPARATE JACUZ TUBS, 2 COMMOM 1/2 BATH, BLDG 100% ; 100% SPRINKERS; EXTENSIVE WOODWORK, LOW POST BMU; REMOVED CARD #2 - NO LONGER ON THIS LOT PAID TAXES AT CLOSING

History Of Taxable Values

Tax Year	Building	Features	Land	Value Method	Total Taxable
2024	\$1,052,900	\$25,900	\$380,600	Cost Valuation	\$1,459,400
2023	\$1,052,900	\$25,900	\$380,600	Cost Valuation	\$1,459,400
2022	\$1,052,900	\$25,900	\$380,600	Cost Valuation	\$1,459,400
2021	\$681,300	\$24,500	\$271,200	Cost Valuation	\$977,000
2020	\$681,300	\$24,500	\$271,200	Cost Valuation	\$977,000
2019	\$681,300	\$24,500	\$271,200	Cost Valuation	\$977,000
2018	\$681,300	\$24,500	\$271,200	Cost Valuation	\$977,000
2017	\$681,300	\$24,500	\$271,200	Cost Valuation	\$977,000
2016	\$439,100	\$31,400	\$137,500	Cost Valuation	\$608,000
2015	\$439,100	\$31,400	\$137,500	Cost Valuation	\$608,000
2014	\$439,100	\$31,400	\$137,500	Cost Valuation	\$608,000
2013	\$439,100	\$31,400	\$137,500	Cost Valuation	\$608,000
2012	\$439,100	\$31,400	\$137,500	Cost Valuation	\$608,000
2011	\$439,100	\$31,400	\$137,500	Cost Valuation	\$608,000
2010	\$721,300	\$5,300	\$205,800	Cost Valuation	\$932,400

Sales

Sale Date	Sale Type	Qualified	Sale Price	Grantor	Book	Page
09/12/2019	IMPROVED	NO - BUSIN AFFIL GRNTR/E	\$840,000	MLB HOSPITALITY CORP	3462	1087
06/09/2010	IMPROVED	NO - FORECLOSURE	\$249,998	GLEN HAVENS LLC	2862	867

Land

Size: 8.307 Ac. **Site:** GOOD
Zone: 01 - TOWN COMM DIST **Driveway:** PAVED
Neighborhood: AVG **Road:** PAVED
Land Use: COM/IND **Taxable Value:** \$380,600

Land Type	Units	Base Rate	NC	Adj	Site	Road	Dway	Topo	Cond	SPI	R	Tax Value	Notes
COM/IND	1.000 AC	82,000	E	100	105	100	100	95 MILD	200	0	N	163,600	USE
COM/IND	7.307 AC	22,000	X	100	0	0	0	90 ROLLING	150	0	N	217,000	USE/WET

Building

2.50 STORY FRAME INN Built In 1900

Roof: GABLE OR HIP **Bedrooms:** 12 **Quality:** AVG+30
 ASPHALT **Bathrooms:** 14.5 **Size Adj.** 0.7442
Exterior: CLAP BOARD **Extra Kitchens:** 0 **Base Rate:** 240.00
Interior: DRYWALL **Fireplaces:** 0 **Building Rate:** 0.9447
Flooring: CARPET **Generators:** 0 **Sq. Foot Cost:** 226.73
 HARDWOOD **AC:** YES **Effective Area:** 8,600
Heat: OIL **Comm. Wall Factor:** 100 **Gross Living Area:** 7,933
 HOT WATER **Comm Wall:** WOOD **Cost New:** \$1,949,878

Depreciation						
Normal	Physical	Functional	Economic	Temporary	Total Dpr.	Assessment
GOOD		LB				
44%	0%	2%	0%	0%	46%	\$1,052,900

Features

Feature Type	Units	Length x Width	Size Adj	Rate	Cond	Value	Notes
COLD STORAGE	96	8 x 12	227	50.00	75	\$8,172	WALKIN
FIREPLACE 1-STAND	1		100	3000.00	100	\$3,000	GAS
SPRINKLERED AREA	7933	1 x 7933	62	3.00	100	\$14,755	
Total:						\$25,900	

Photo





Sketch

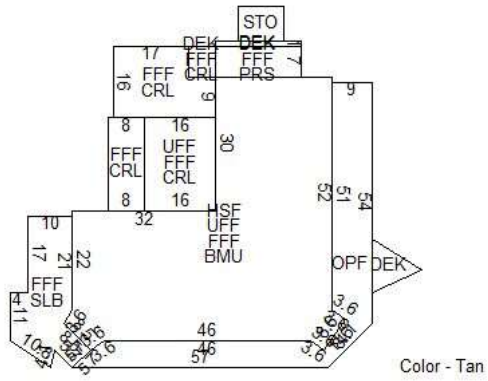

Code	Description	Area	Eff Area	GL Area
HSF	1/2 STRY FIN	2,484	1,242	1,242
UFF	UPPER FLR FIN	2,820	2,820	2,820
FFF	FST FLR FIN	3,871	3,871	3,871
BMU	BSMNT UNFINISHED	2,484	373	0
OPF	OPEN PORCH	842	211	0
DEK	DECK/ENTRANCE	260	26	0
PRS	PIER FOUNDATION	133	-7	0
STO	STORAGE AREA	80	20	0
CRL	CRAWL SPACE	872	44	0
SLB	SLB FOUNDATION	382		0
Totals			8,600	7,933

Printed on 03-28-26